

**FRAME AND LID PLAN
VIEW**

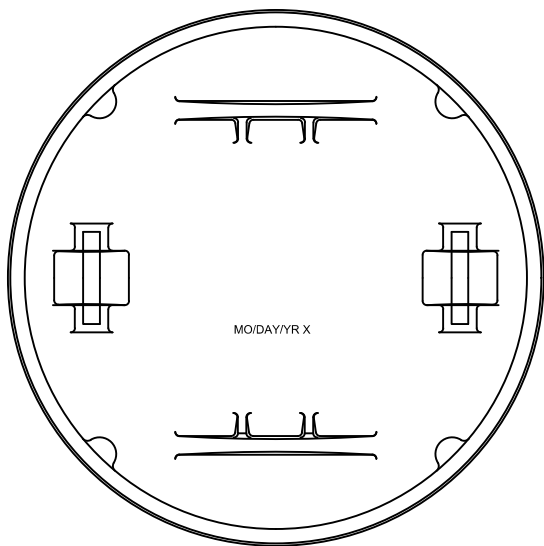

LID VIEW BOTTOM

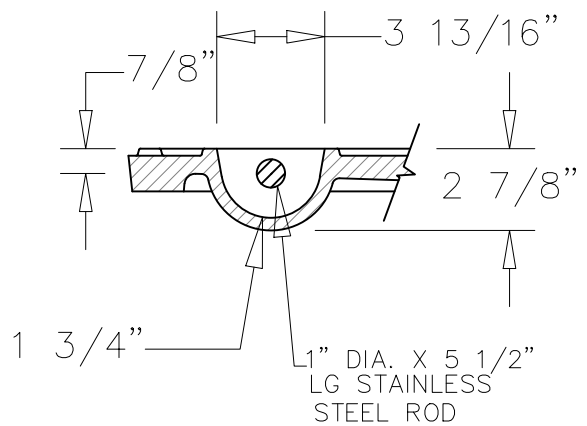

PICKBAR DETAIL

SHT 1 OF 2

The City of San Marcos
Engineering and Capital Improvements

CURRENT AS OF
1/1/2021

**SANITARY SEWER MANHOLE RING AND
COVER 32" - UNBOLTED**

RECORD COPY SIGNED BY
LAURIE MOYER, P.E.

6/5/2014
ADOPTED

THE ARCHITECT/ENGINEER ASSUMES
RESPONSIBILITY FOR APPROPRIATE
USE OF THIS STANDARD

503S-4W-SM
N.T.S. STANDARD DETAIL

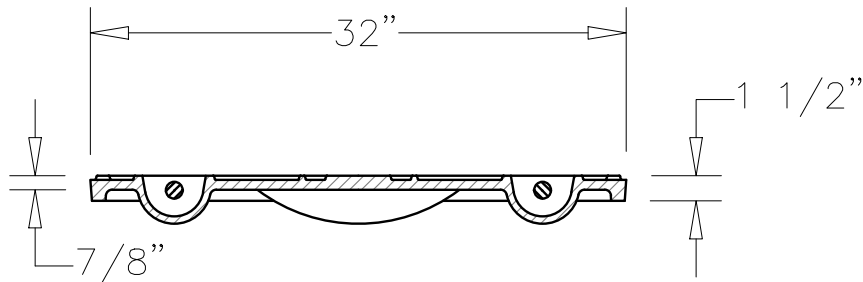

LID SECTION VIEW

SECTION A-A

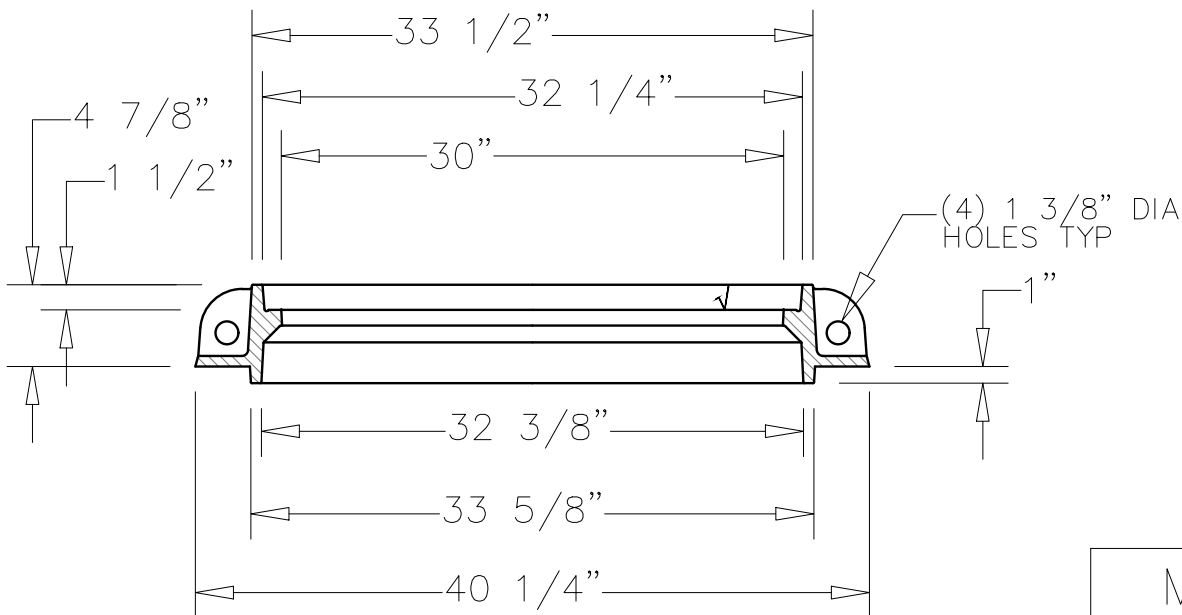

FRAME SECTION VIEW

SECTION A-A

MATERIALS	
LID	DUCTILE IRON
FRAME	GRAY IRON

NOTE:

1. THIS DETAIL IS FOR USE IN PUBLIC INFRASTRUCTURE ONLY. PRIVATE INFRASTRUCTURE WILL NOT HAVE CITY OF SAN MARCOS LOGO.
2. COVER SHALL BE EAST JORDAN IRON WORKS OR APPROVED EQUIVALENT.

SHT 2 OF 2

The City of San Marcos
Engineering and Capital Improvements

CURRENT AS OF
1/1/2021

**SANITARY SEWER MANHOLE RING AND
COVER 32" - UNBOLTED**

RECORD COPY SIGNED BY

6/5/2014

THE ARCHITECT/ENGINEER ASSUMES
RESPONSIBILITY FOR APPROPRIATE
USE OF THIS STANDARD

LAURIE MOYER, P.E.

ADOPTED

503S-4W-SM

N.T.S. STANDARD DETAIL